

Description

Needle valve model NL, NLW are two way, seat type valves.

These are used for isolating the oil flow in the direction as indicated by an arrow mark shown on the valve body.

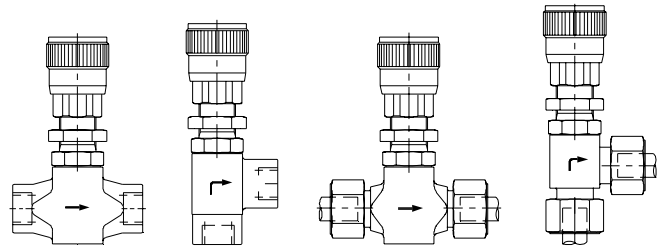

Section

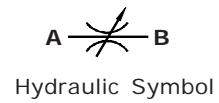
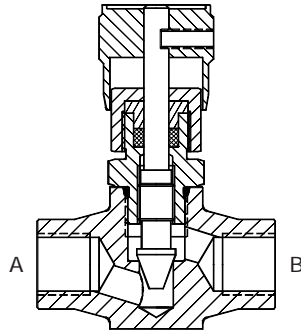

Unit Dimensions

In - line and Right angle bodies (With BSP ports)

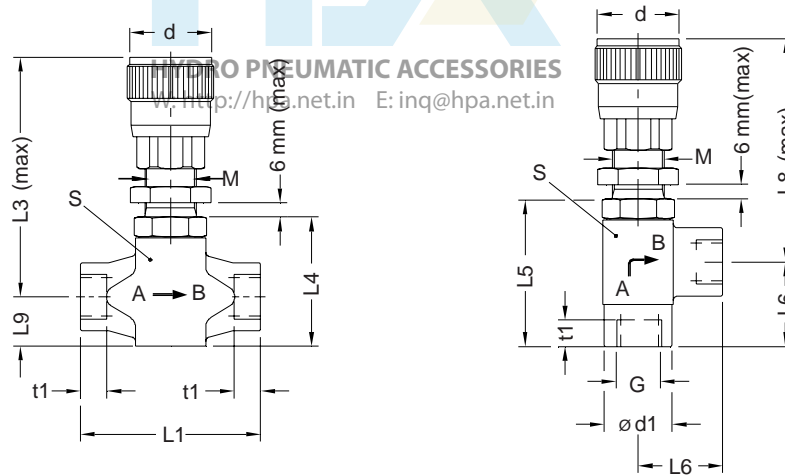

Table 1

Model Code In-line	Model Code Right angle	G	L1	L3	L4	L5	L6	L8	L9	d	t1	S	M
NLG02-2.0	NLWG02-2.0	G 1/4	70	110.5	54.5	56.5	30	103.5	21.0	37	14	30	M22x1.5
NLG03-2.0	NLWG03-2.0	G 3/8	70	110.5	54.5	56.5	30	103.5	21.0	37	14	30	M22x1.5
NLG04-2.0	NLWG04-2.0	G 1/2	77	110.5	54.5	62.5	36	103.5	21.0	37	17	30	M22x1.5
NLG06-2.0	NLWG06-2.0	G 3/4	93	122.0	71.0	77.0	45	110.0	27.0	48	17	36	M26x1.5
NLG08-2.0	NLWG08-2.0	G1	93	122.0	72.0	77.0	45	110.0	27.0	48	18	46	M26x1.5
NLG10-2.0	NLWG10-2.0	G1.1/4	162	162.0	105.0	113.0	65	143.0	51.5	68	22	60	M42x2.0
NLG12-2.0	NLWG12-2.0	G1.1/2	162	162.0	105.0	113.0	65	143.0	51.5	68	24	60	M42x2.0

Needle Valve - Inline and Right angle



the right connection

Ref. No : H02310, Release Jan 2006 (Dimensions in mm)

Unit Dimensions

In - line and Right angle bodies (With Tube ends)

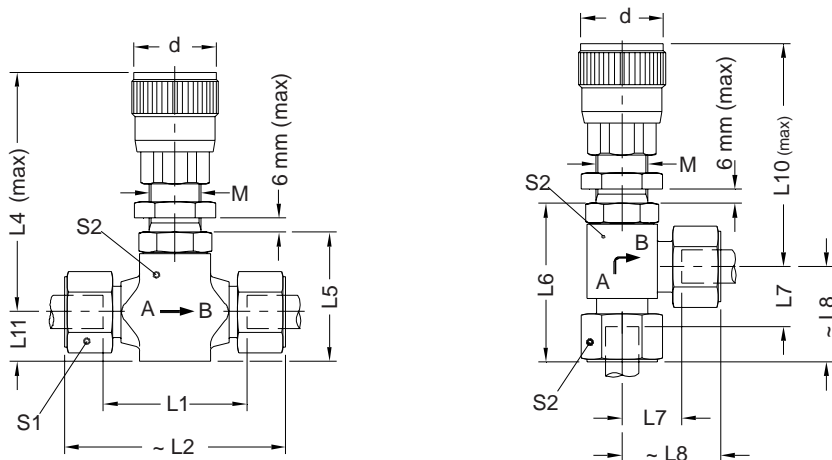

Table 2

Model Code In-line	Model Code Right angle	Tube OD	L1	L2	L4	L5	L6	L7	L8	L10	L11	d	S1	S2	M
NL10S-2.0	NLW10S-2.0	10	55	88.0	110.5	54.5	65.5	22.0	39.0	103.5	21	37	22	30	M22x1.5
NL12S-2.0	NLW12S-2.0	12	55	88.0	110.5	54.5	65.5	22.0	39.0	103.5	21	37	24	30	M22x1.5
NL16S-2.0	NLW16S-2.0	16	60	97.0	110.5	54.5	67.5	22.0	41.0	103.5	21	37	30	30	M22x1.5
NL20S-2.0	NLW20S-2.0	20	72	115.0	122.0	71.5	77.0	28.0	68.0	110.0	28	48	36	41	M26x1.5
NL25S-2.0	NLW25S-2.0	25	69	117.0	122.0	71.5	82.5	28.0	73.5	110.0	28	48	46	41	M26x1.5
NL30S-2.0	NLW30S-2.0	30	135	188.0	162.0	118.0	111.0	40.0	63.0	143.0	52	68	50	60	M42x2.0
NL38S-2.0	NLW38S-2.0	38	130	192.0	162.0	118.0	115.0	40.0	67.0	143.0	52	68	60	60	M42x2.0

HYDRO PNEUMATIC ACCESSORIES

W: <http://hpa.net.in> E: inq@hpa.net.in

Technical Specifications

- Construction Seat type valve.
- Mounting style In-line or Right angle body, line mounted.
- Mounting position Optional.
- Flow direction As indicated by an arrow on valve body.
- Operating pressure 350 bar.
- Hydraulic medium Mineral oil.
- Viscosity range 10 cSt to 380 cSt.
- Fluid temperature range -20 °C to +80 °C.
- Fluid cleanliness requirement As per ISO 19/16 or better.
- Maximum flow handling capacity Refer graph.

Performance Curves

Oil used : ISO VG 68,
 Viscosity : 68 cSt @ 40 °C
 Test conducted at : 50 °C.

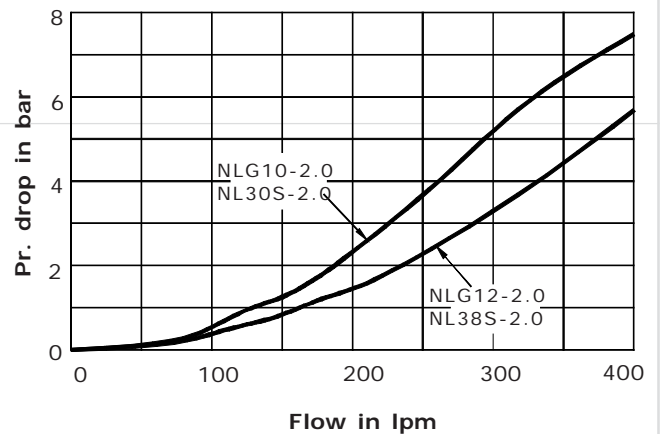
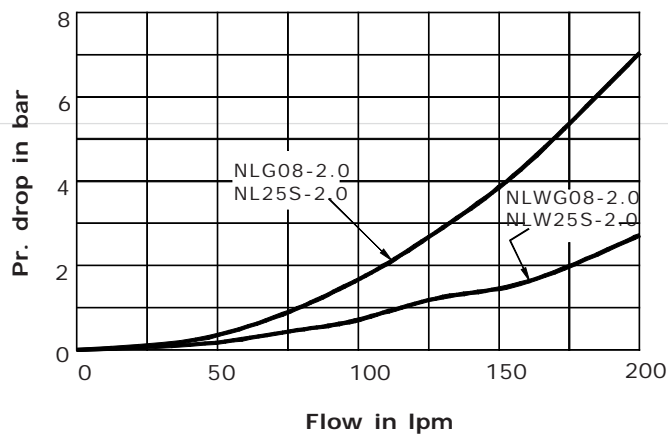
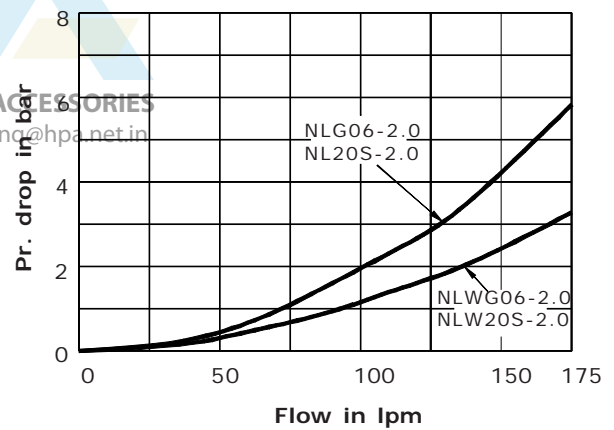
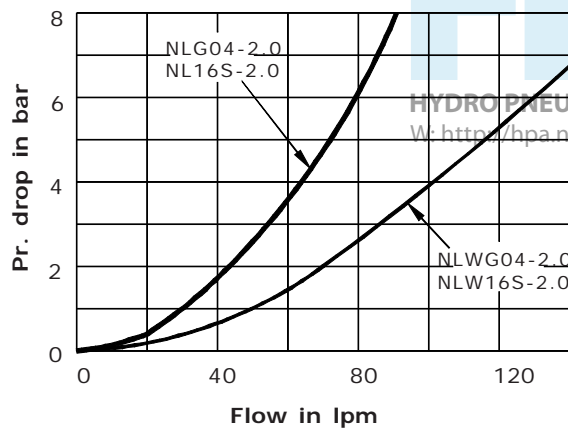
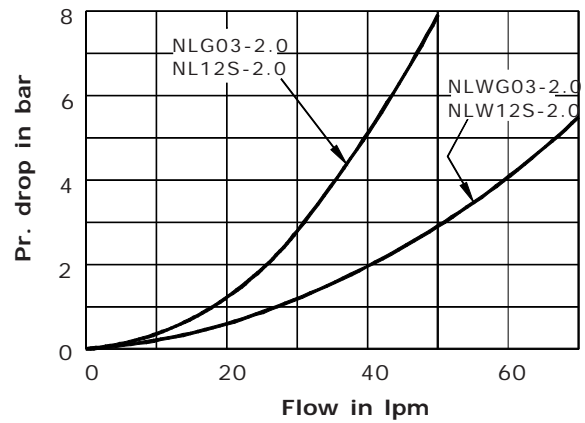
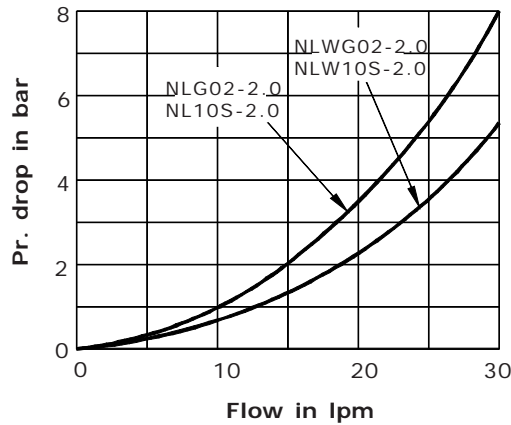

Needle Valve - Inline and Right angle



the right connection

Ref. No : H02310, Release Jan 2006 (Dimensions in mm)

Ordering Code

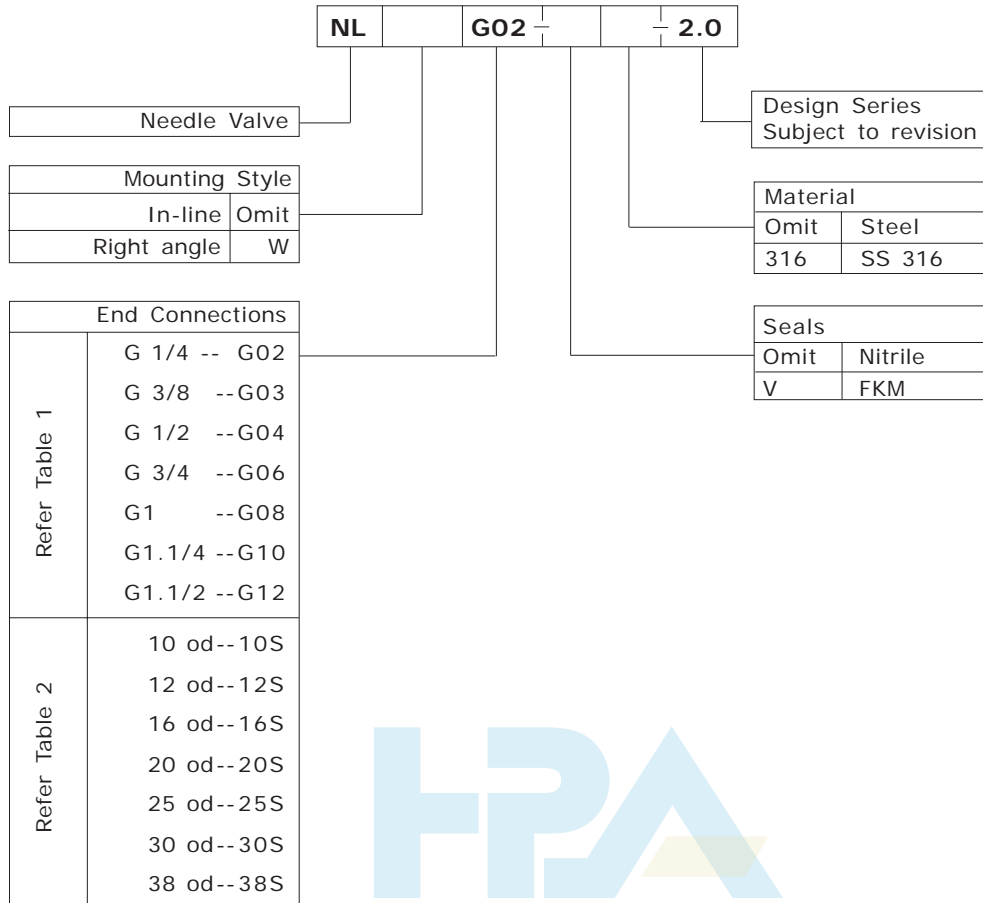

HYDRO PNEUMATIC ACCESSORIES
 W: <http://hpa.net.in> E: inq@hpa.net.in