



FLOW CONTROL VALVE

Series GR2

Cat No GR2 - 01 - 03

FLOW CONTROL VALVE - Inline type

Features

- ❑ Fine regulation of air flow
- ❑ Elegant design and finish



Function

These valves allow controlled flow of air in one direction and free flow in the other direction.

Application

These valves are used to control the speed of the pneumatic cylinder.

Technical Specifications

Type	Reversing type
Model	GR011
Medium	Compressed air - Dry / Lubricated
Operating pressure range	10 bar
No. of needle rotations	8
Ambient Temperature	5° - 60° C
Materials of construction	Brass, Acetal, Nitrile
Applicable tubes	Nylon, Polyurethane

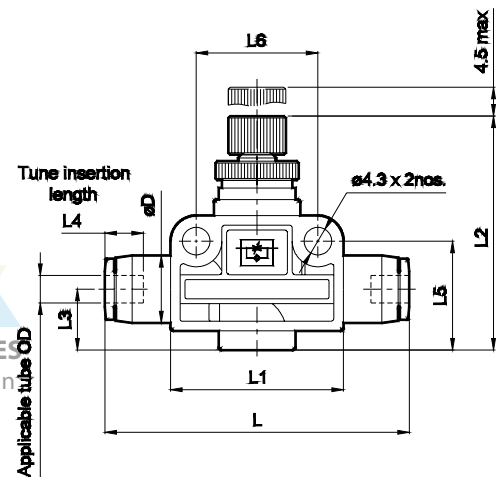

Sl. No	Ordering No.	Applicable Tube OD	L	L1	L2	L3	L4	L5	L6	ØD1	Free Flow Lts/min. @	Controlled Flow Lts/min. @
1	GR0110404	4	49.5	27	37.5	9.5	14.5	17	19	10.5	50	50
2	GR0110606	6	55	32	43.5	11	15.5	19.5	24	12.5	225	200
3	GR0110808	8	58	32	43.5	11	17.5	20.5	24	15	450	400
4	GR0111010	10	68.5	33	48	12	20	23.5	25	18.5	800	550
5	GR0111212	12	68.5	33	48	12	20.5	24.5	25	21	950	900

@ Inlet pressure 6 bar, and pressure drop 1 bar

How to Order

While ordering Flow control valve, mention the ordering number given in the corresponding tables.

Subject to change