



# RADIAL PISTON PUMP 11RC

ENGINEERING

1

Ref. No. P09206

Release 12/2007

## Description

Radial piston arrangement, with 5 or 7 pumping elements. External mounting type. Face mounting, Valve controlled, Fixed delivery. Bi-directional rotation of shaft. Available with extension shaft for through drive. With extension bracket assembly for coupling a low pressure pump having standard flange.



## Section

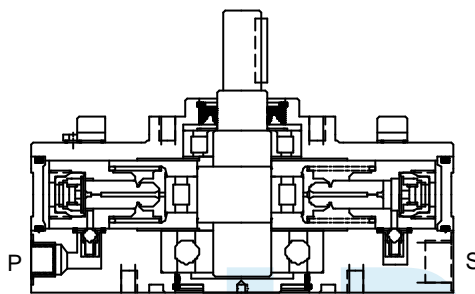

Hydraulic Symbol



## Unit Dimensions

Dimensions in mm.

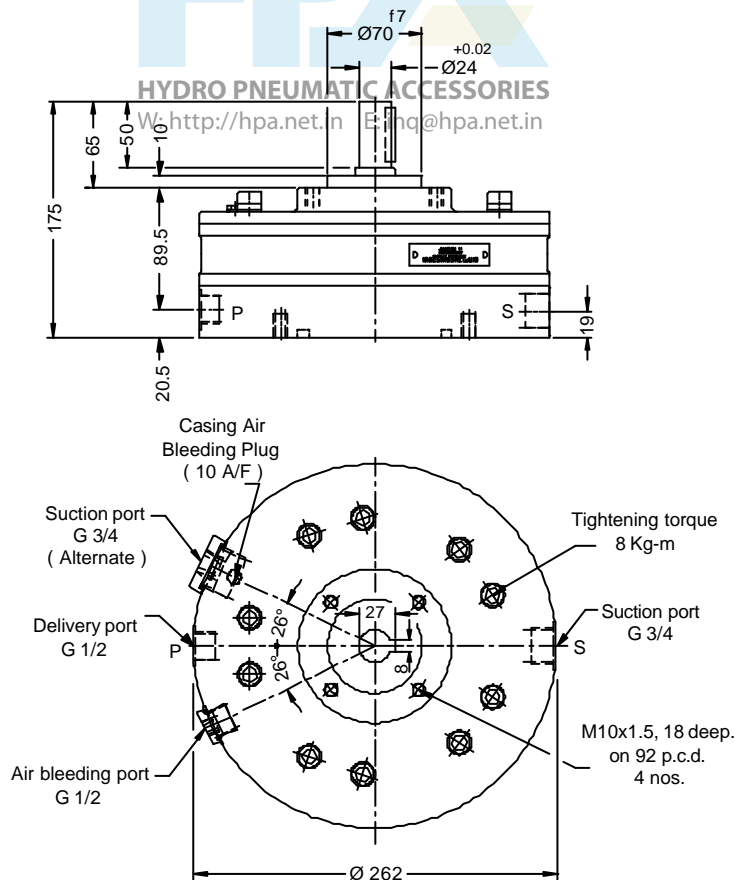

**Polyhydron Pvt. Ltd.**  
78-80, Machhe Industrial Estate, Machhe,  
Belgaum - 590 014. INDIA.

**Phone** : +91-(0)831-2411001  
**Fax** : +91-(0)831-2411002  
**E-mail** : [polyhydron@vsnl.com](mailto:polyhydron@vsnl.com)  
**Website** : [www.polyhydron.com](http://www.polyhydron.com)



# RADIAL PISTON PUMP 11RC

**ENGINEERING**

**2**

**Ref. No. P09206**

## Technical Specifications

Designation .....	11RC basic radial piston pump group.
Design .....	Radial piston, valve controlled.
No. of pistons .....	5 or 7; depending upon flow requirement.
Mounting .....	Face mounting.
Interface .....	Factory standard.
Direction of rotation .....	11RC ..... Can be run in either direction.
	11RCE ... Depends upon the direction of rotation of pump attached.
Connection .....	Suction ... G 3/4 female Suction head — The oil level can be max. 300 mm below the suction port of the pump. Suction pipe size — 25 o. d. x 2 th. (as far as possible use straight pipe)
	Delivery ... G 1/2 female.
Speed range .....	1000 to 2000 rpm.
Hydraulic medium .....	Mineral oil.
Viscosity range .....	10 to 100 cSt.
Optimum Viscosity range .....	16 to 32 cSt.
Temperature range .....	-10 °C to +80 °C. (Do not exceed viscosity limits at extreme temperatures for efficient running of the pump)
Fluid cleanliness requirement .....	As per ISO Code 16/13.
Performance .....	Refer Table.
Mass .....	26kg.
Suction pressure .....	0.02 to 3 bar positive

**HYDRO PNEUMATIC ACCESSORIES**  
W: <http://hpa.net.in> E: [inquiry@hpa.net.in](mailto:inquiry@hpa.net.in)

Table

Code No.	Geometrical displacement CC / REV	Rated output at 1450 rpm l / min	Rated output at 1450 rpm & 95% efficiency l/min.	Operating pressure bar	Input power requirement ( @ 1450 rpm & 95% efficiency)																	
					50 bar		100 bar		150 bar		200 bar		250 bar		300 bar		315 bar		350 bar		400 bar	
					KW	hp	KW	hp	KW	hp	KW	hp	KW	hp	KW	hp	KW	hp	KW	hp	KW	hp
5A	7.7	11.2	10.6	400	1	1.4	2.1	2.8	3.1	4.2	4.1	5.6	5.1	7	6.2	8.4	6.5	8.8	7.2	9.8	8.2	11.1
7A	10.8	15.7	14.9	400	1.4	2	2.9	3.9	4.3	5.9	5.8	7.8	7.2	9.8	8.7	11.8	9.1	12.3	10.1	13.7	11.5	15.7
5B	10.1	14.7	14	315	1.4	1.8	2.7	3.7	4.1	5.5	5.4	7.3	6.8	9.2	8.1	11	8.5	11.6				
7B	14.1	20.5	19.5	315	1.9	2.6	3.8	5.1	5.7	7.7	7.5	10.2	9.4	12.8	11.3	15.4	11.9	16.1				
5C	12.7	18.5	17.6	250	1.7	2.3	3.4	4.6	5.1	6.9	6.8	9.2	8.5	11.5								
7C	17.8	25.8	24.5	250	2.4	3.2	4.7	6.4	7.5	9.7	9.5	12.9	11.9	16.1								

Note : The first digit in the code No. indicates No. of pumping elements in the pump. The second letter indicates flow and pressure rating of the pumping elements.

Code No. 7C for example, indicates a pump with 7 pumping elements having rated flow of 24.5 l / min and operating pressure upto 250 bar.



# RADIAL PISTON PUMP 11RC

ENGINEERING

3

Ref. No. P09206

## Accessories

**Extension shaft** (For through drive)  
Unit dimensions

M16x2, 26 deep.  
2 nos. on 155 p.c.d.

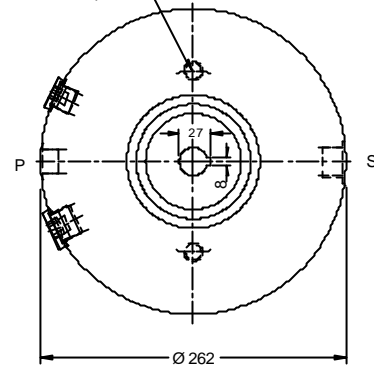

Note :  
Torque limitation :- The sum of torque used for the piston pump and torque used at extended shaft end should not exceed 148 Nm. ( 22.2 kW @ 1450 rpm)

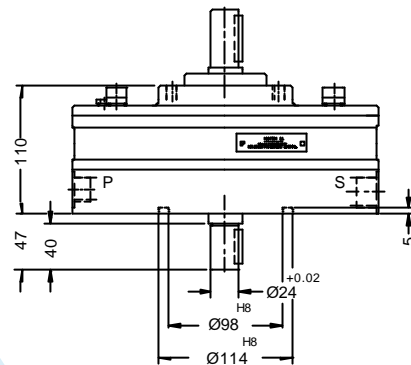

## Ordering Code

HYDRO PNEUMATIC ACCESSORIES  
W: <http://hpa.net.in> E: [inq@hpa.net.in](mailto:inq@hpa.net.in)

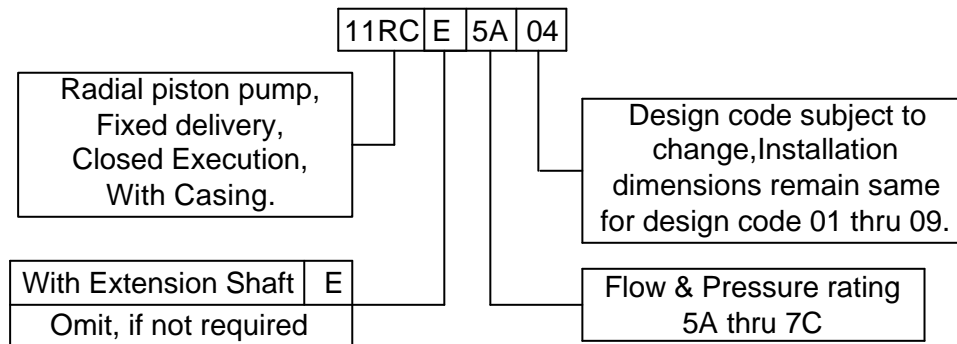

Note : For Bell housing assembly Refer Sheet No. P09035.  
For Extension bracket assembly Refer Sheet No. P09090.

## Sectional view & Parts Detail

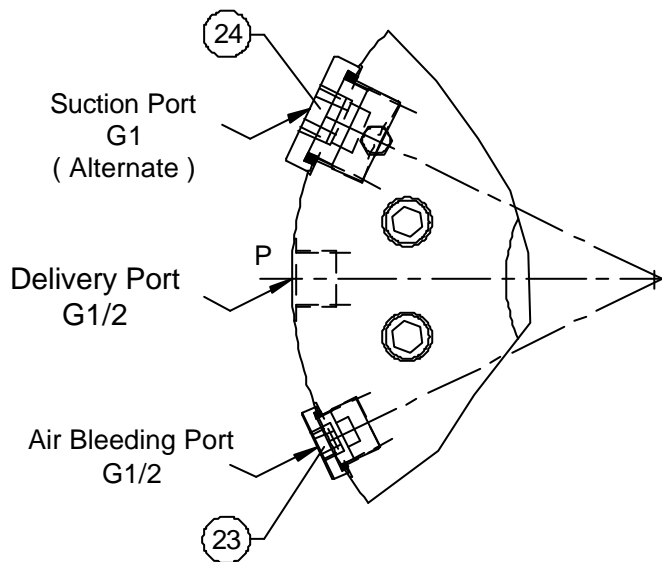
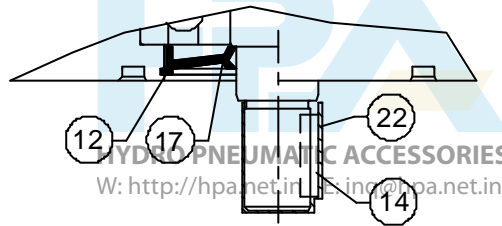
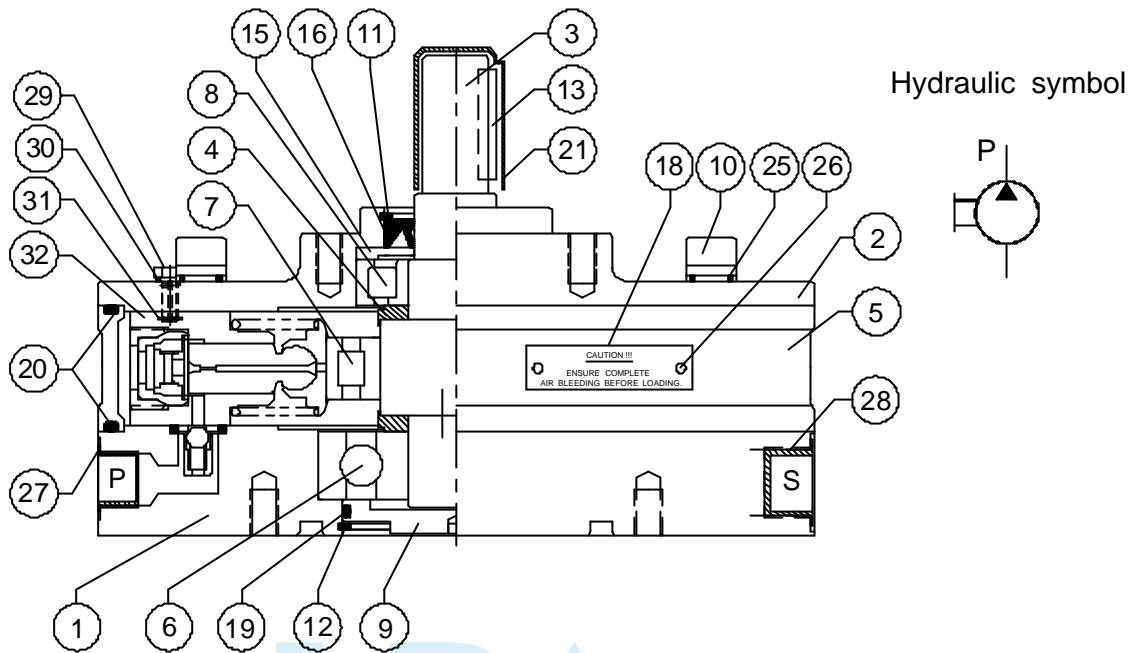

Note :-

Specified part numbers are available as spares.  
\* Recommended seal kit.



# RADIAL PISTON PUMP 11RC

ENGINEERING

6

Ref. No. P09206

## Sectional view & Parts Detail

Sl.No.	Description	11RC 5/7		11RCE 5/7		Size	Qty.
		Part No.	Part No.	Part No.	Part No.		
1	Valve plate	12202 / 12204	12202 / 12204				1
2	Cover plate	12222 / 12224	12222 / 12224				1
3	Shaft	12241	12242				1
4	Balancing Plate	12251					2
5	Casing Ring	12231					1
6	Bottom Bearing	12261				KOYO 6407	1
7	Centre Bearing.	12262				NUP 2206	1
8	Top Bearing.	12263				NJ 207	1
9	End cap	12253	---			Ø82	1
10	Cap screw	12264				M12x70 L	10/14
11	Circlip	12272				Ø52 (Type B)	1
12	Circlip	12273				Ø82 (Type B)	1
13	Shaft Key	12277				8x7x40	1
14	Shaft Key	---	12278			8x7x30	1
15	Washer	12281					1
* 16	Rotary shaft seal	12266				Dou.Lip 52	1
* 17	Rotary shaft seal	---	12267			Dou.Lip 82	1
18	Label (Caution)	12269				4P 05613	1
19	O' Ring	12274	---			76x3	1
20	O' Ring	12276				246x4	2
21	Plastic cap	12270				11R	1
22	Plastic cap	---	12271			11RE(Shaft)	1
23	Elastomeric Plug	00204				G 1/2	1
24	Elastomeric Plug	00205				G 3/4	1
25	Bonded Seal	00165				M12	10/14
26	Rivet	00001				Ø2, 4.5 L	2
27	Rubber Port Plug	00011				G 1/2 Plug Cap	1
28	Rubber Port Plug	00012				G 3/4 Plug Cap	1
29	Hex Plug	11299				M6x16	1
30	Copper washer	11297				Ø6.5xØ9.5x1	1
31	External Circlip	00065				Dia. 4 Nom.	1
Sl.No.	Description	Product				Qty.	
32	Pump element assly. (Refer Data Sheet No. A 12100)	11R-A-01 11R-B-01 11R-C-01				5 / 7	

All rights reserved.  
Subject to revision.



# RADIAL PISTON PUMP 11RC

ENGINEERING

6

Ref. No. P09206

## Maintenance Manual

MODEL : 11RC

Commissioning and Maintenance Instructions :

Polyhydron make Radial Piston Pumps are reliable hence require very little attention from user. However it is necessary that following points must be kept in mind while storage, assembly, commissioning and maintenance.

### Storage :

For open execution type, it is necessary that during storage the pumps must be properly covered and well lubricated. This will prevent the ingress of dust/dirt in the working mechanism and during commissioning it will be easy to install the same.

### Assembly :

During assembly take care to align the pump properly with respect to the electric motor or other driving mechanism. During assembly take care to align the pump properly with respect to the electric motor or other driving mechanism. Badly aligned pumps will damage the bearings very fast. Badly machined flexible couplings will damage the bearings and the key in very short time. The flexible couplings used to drive the pump must be of good quality. For open execution type it is necessary that the pumps must be properly immersed in the oil for its efficient and smooth working. The proportions of the tank should be adequate so that even after the maximum displacement of the oil from the tank the oil level should not fall below the minimum level for the pump. Please remember that the pump always needs its suction valves flooded with oil. During assembly / installation provide a check valve with low or almost nil cracking pressure on the suction pipe and fill up the casing with oil before starting the pump. To be on safer side keep also the delivery port open. For casing pumps the maximum negative suction head should not exceed 300 mm. The suction pipe should be 25 O.D. x 3 mm Th. and preferably straight.

### Commissioning :

During commissioning the delivery port should be left open till you get full / uninterrupted flow. (The pump need not have a check valve as mentioned below provided the oil level is not exceeding 300 mm below the pump suction port). This is not required to be done every time you start the pump after short durations ( a day or two ) of non-operation.

For casing type ensure the total removal of air inside the casing.

The direction of rotation of the pump is not important. However if the pump is coupled to any other make pump, then the direction of rotation of the pump depends on the coupled pump.

### Maintenance :

The radial piston pumps do not need any major attention, but to ensure its efficient working and long life of the pump it is necessary that the following points kept in mind:

The oil must be of prime quality and clean as per ISO code 16/13.

Care should be taken that the oil should be periodically changed. The use of Contaminated oil may damage suction valves and bearings.

For optimum performance the viscosity of the oil at operating temperature should be in the range of 40 – 70 cSt. In case if you disassemble the pump use 5 kg-m torque for tightening the cap screws.

**PRIMING PROCEDURE FOR CLOSED EXECUTION PUMP - 11RC**

**A] When the Casing Pump is mounted Horizontally.**

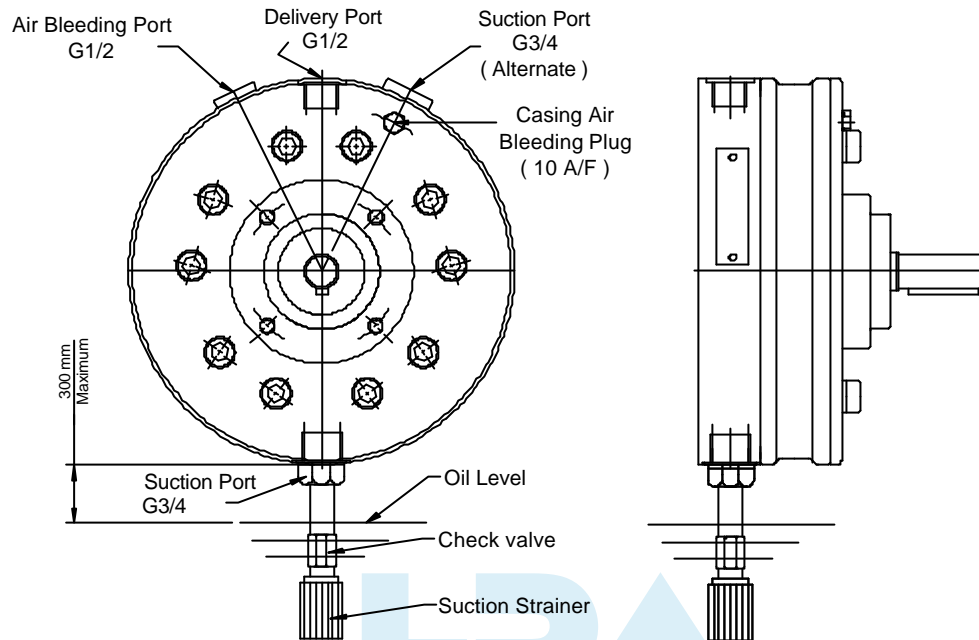

**Case I : When the pump suction port height exceeds 300 mm above oil level.**

- 1) During assembly / installation provide a check valve with almost nil cracking pressure on the suction pipe. ( Refer check valve model codes given below).
- 2) Fill up the casing with oil (Use Alternate Suction port - G3/4 BSP & ensure it to be air tight after filling).
- 3) Connect a Hose pipe of suitable size to the air bleeding port - G 1/2 BSP.
- 4) Now, switch on the motor & wait for some time till you get full / uninterrupted flow.
- 5) As soon as you get the uninterrupted flow, switch off the motor & plug the Air Bleeding port.
- 6) Now, run the pump for short period at no load.
- 7) Adjust the system main pressure relief valve to a required value and start using the system.

**Case II: When the pump suction port height is less than 300 mm above oil level.**

- 1) The pump need not have a check valve as mentioned above.
- 2) During commissioning the Air bleeding port should be kept open to tank by connecting a hose pipe.
- 3) Now, repeat the steps 4 to 7 of case -I.

## PRIMING PROCEDURE FOR CLOSED EXECUTION PUMP - 11RC

### B] When the Casing Pump is mounted Vertically

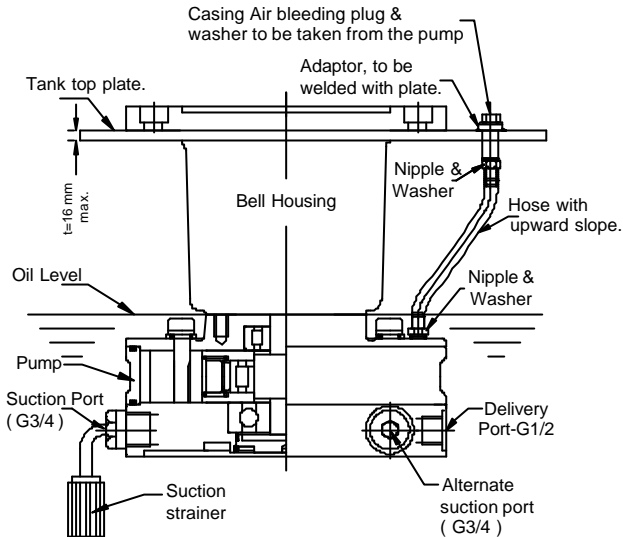

#### Case I: When the casing pump is immersed in oil.

- 1) Make the connection for air bleeding as shown in fig. using the kit provided with the pump.
- 2) Loosen the Casing air bleeding plug completely.
- 3) Wait for some time for the oil to fill the pump casing.
- 4) The plug may now be retighten.
- 5) Now run the pump for short period at no load.
- 6) Adjust the main pressure relief valve of the system at required value and start using the system.

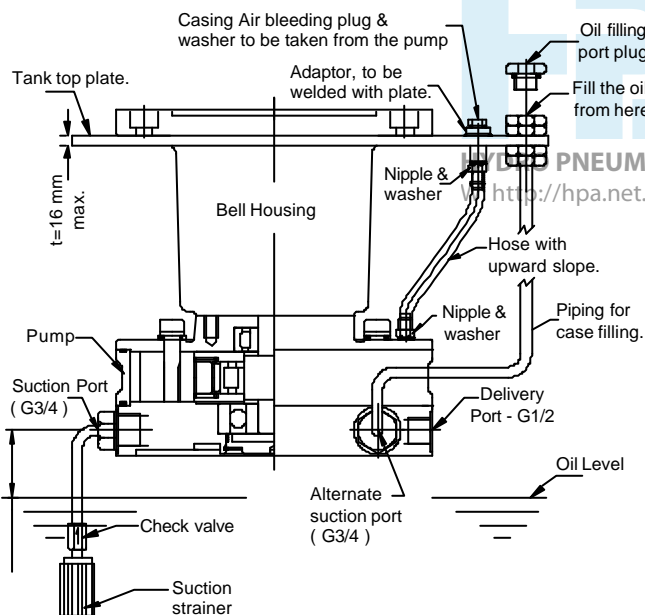

#### Case II: When the oil level is below the suction port (i.e up to a distance of 300mm. Maximum).

- 1) Make the connection for air bleeding as shown in fig. using the kit provided with the pump.
- 2) Fit a check valve with almost nil cracking pressure at the bottom of the suction pipe. ( Refer check valve model codes given below).
- 3) Now fill the pump casing with oil. This can be done by providing a pipe connection to alternate suction port as shown.
- 4) Now loosen the casing air bleeding plug completely & fill the casing till oil is seen coming out of casing air bleeding port.
- 5) Tighten the casing air bleeding plug once the casing is filled. Also, plug the oil filling port & ensure it to be air tight.
- 6) Now run the pump at no load for some time. .
- 7) Adjust the main pressure relief valve of the system at required value and start using the system.

**Note :** Priming is not required to be done every time you start the pump after short durations (a day or two) of non-operation.

#### Suction pipe specification

- 1) 1R-series :— 16 O.D.x 2 mm thick (Preferably straight) for Single row pump.
- 2) 2R-series :— 25 O.D.x 2 mm thick (Preferably straight) for Double row pump.
- 3) 11R-series :— 25 O.D.x 2 mm thick (Preferably straight) for Single row pump.
- 4) 12R-series :— 30 O.D.x 2 mm thick (Preferably straight) for Double row pump.

#### Check valve model codes ( To be ordered separately)

- 1) 1R-series :— C10T0-03
- 2) 2R-series :— C15T0-04
- 3) 11R-series :— C20T0-03
- 4) 12R-series :— C20T0-03