



PILOT OPERATED PRESSURE REDUCING VALVE PPM

ENGINEERING

1

Ref. No. P06281

Release 02/2009

Description

Two stage pilot operated construction. These valves are normally open type valves. When the pressure in the secondary port (port A) increases to set pressure, the valve closes against the spring. For reverse free flow, the valve can be supplied with a modular check valve. (To be ordered separately)



Section

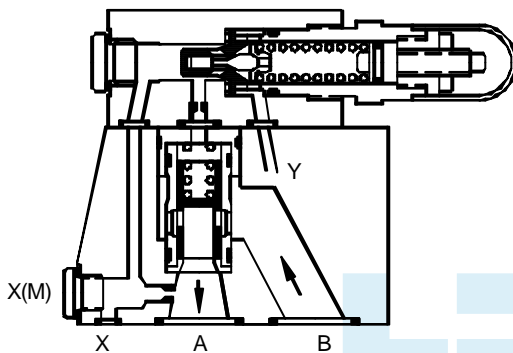

Hydraulic Symbol



Unit Dimensions

Valve : Subplate mounting

Table 1

Size	10	20	30
H1	121	124	146
H2	75	75	75
H3	12	12	14
L1	155	157	170
L2	84	100	128
L3	31	28.9	31.8
L4	--	--	42.1
L5	42.9	60.3	84.1
W1	88	100	120
W2	66.7	79.4	96.8

Table 2

Size	Valve fixing screws	Tightenin torque
10	M10 X 90 L, 4 Nos.	70 Nm
20	M10 X 90 L, 4 Nos.	70 Nm
30	M10 X 90 L, 6 Nos.	70 Nm

HYDRO PNEUMATIC ACCESSORIES
W: <http://hpa.net.in> E: inquiry@hpa.net.in

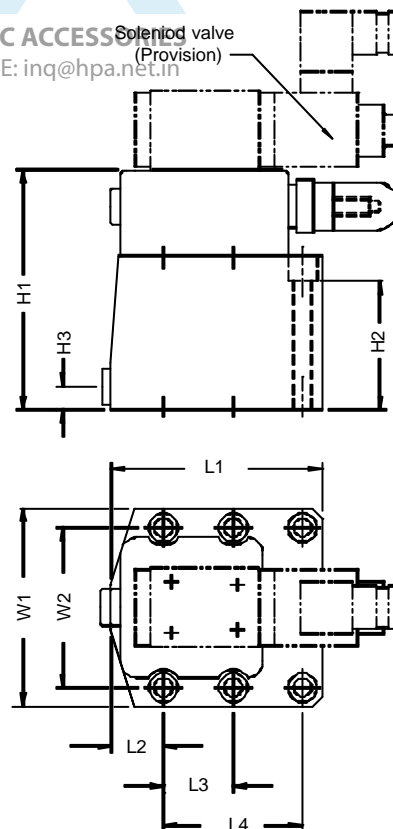

Dimensions in mm.

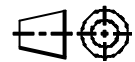

Polyhydron Pvt. Ltd.
78-80, Machhe Industrial Estate,
Machhe, Belgaum - 590 014. INDIA.

Phone : +91-(0)831-2411001
Fax : +91-(0)831-2411002
E-mail : polyhydron@gmail.com
Website : www.polyhydron.com



PILOT OPERATED PRESSURE REDUCING VALVE PPM

ENGINEERING

2

Ref. No. P06281

Valve : Threaded body

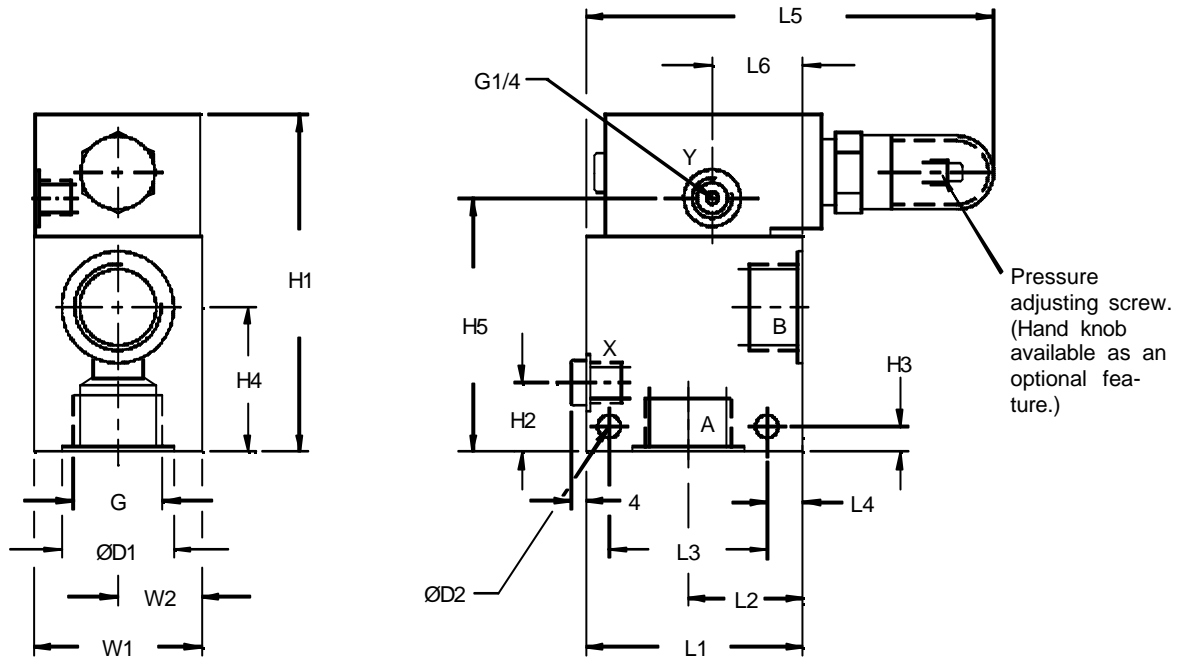
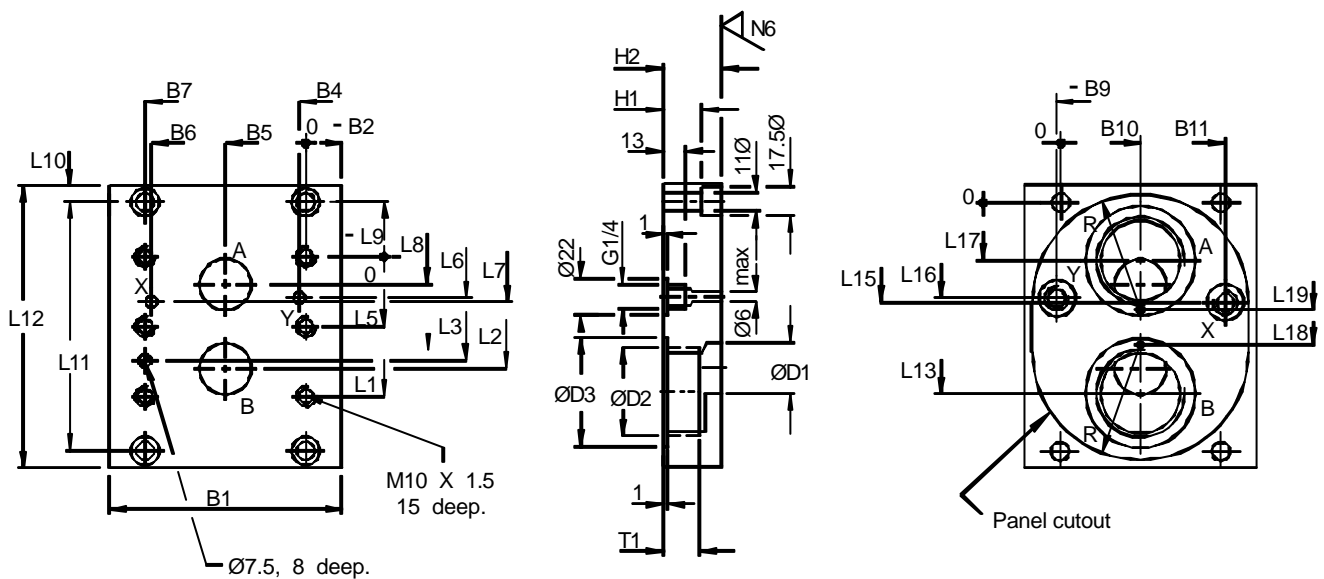

Table 3

Size	G	H1	H2	H3	H4	H5	L1	L2	L3	L4	L5	L6	W1	W2	ØD1	ØD2
20	G1	134	27	10	57	100	85	45	62	14	157	35.5	66	33	44	9
30	G1 1/2	173	42	13	80	138	100	54	72	18	168	41.5	86	43	60	1

HYDRO PNEUMATIC ACCESSORIES
W: <http://hpa.net.in> E: inquiry@hpa.net.in

Subplate (Not in Supply) details are only for reference





**PILOT OPERATED
PRESSURE REDUCING VALVE
PPM**

ENGINEERING

3

Ref. No. P06281

Table 4

Size	Model	Mass kg	B1	B2	B4	B5	B6	B7	B9	B10	B11	ØD1	ØD2	ØD3	H2	H1	L1	L2
10	1SP06G03	2.4	86	9.7	7.9	33.3	58.7	66.7	-7.9	33.3	58.7	13	G 3/8	25	29	15	42.9	35.7
	G 1/2												30					
20	1SP08G06	5.2	112	16.3	6.4	39.7	73	79.4	3	39.7	75	22	G 3/4	36	45	25	60.5	49.2
	G1												44					
30	1SP09G10	8.5	140	21.6	4	48.4	92.9	96.8	1.6	48.4	98.5	31	G1 1/4	54	47	35	84.1	67.5
	G1 1/2												60					

Size	Model	L3	L5	L6	L7	L8	L9	L10	L11	L12	L13	L15	L16	L17	L18	L19	R	T1
10	1SP06G03	31.8	--	21.4	21.4	7.1	45.9	10	121	141	87	67.3	67.3	47	82	53	40	12
	89										45		14					
20	1SP08G06	44.5	--	39.7	20.8	11.1	22	16	104	136	77	42.6	64	27	57	47	52	16
	82										22		18					
30	1SP09G10	62.7	42.1	59.6	24.6	16.7	33	10	150	170	111	60	99.1	39	90	60	65	20
	115										35		22					

Technical Specifications

ConstructionTwo stage pilot operated valve.
 Mounting typeSubplate mounting conforming to ISO 5781,
 Threaded conforming to factory standard.
 Mounting positionOptional
 Flow directionFrom port 'B' to port 'A'
 Inlet pressure at port 'B' 315 bar
 Outlet pressure at 'A'5 to 315 bar
 Max. back pressure at port 'Y' 315 bar
 Hydraulic mediumMineral oil
 Viscosity range10 cSt to 380 cSt.
 Fluid temperature range -20 °C to +70 °C
 Fluid cleanliness requirement As per ISO 16/13
 Maximum flow handling capacity For valve size 10 80 l/min.
 20 200 l/min.
 30 300 l/min.
 PerformanceRefer graph.
 Mass (in kg.)

Size	Subplate type	Threaded type
10	5.5	9
20	7.7	9
30	13.5	11



**PILOT OPERATED
PRESSURE REDUCING VALVE
PPM**

ENGINEERING

4

Ref. No. P06281

Performance Curve

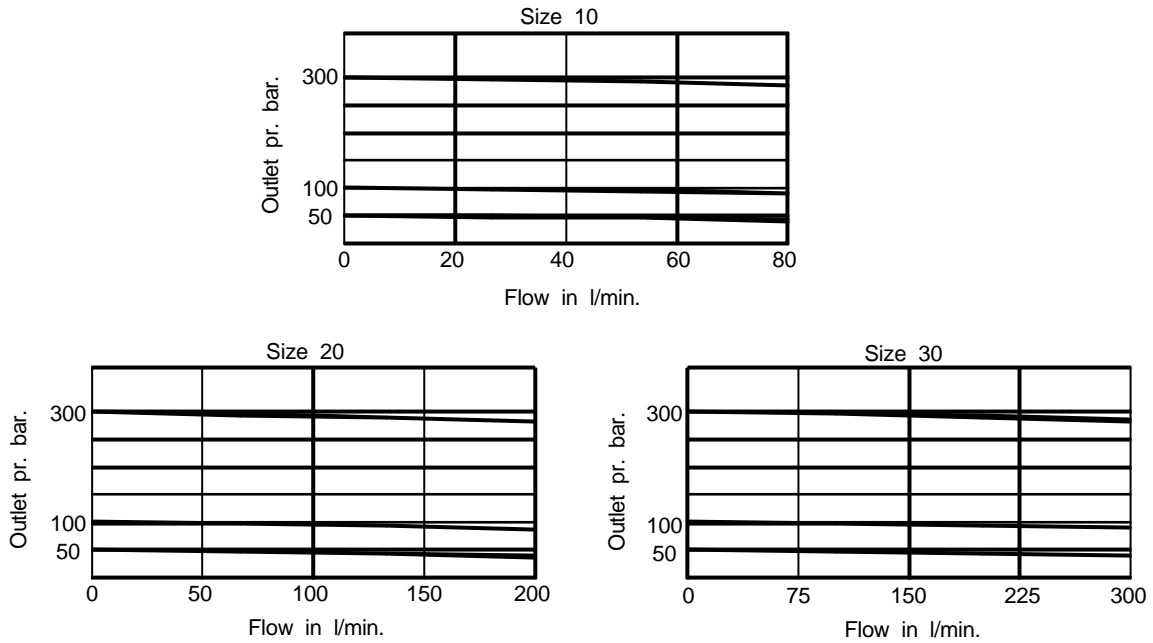

Ordering Code

PPM | H | 10 | S | 50 - 22

Direct acting Pressure reducing valve

Hand knob	H
Set screw	S

For subplate mounting
Size 10, 20 or 30

For threaded body size
20 & 30

Design code subject to change. Installation dimensions remain same. for design code 20 thru 29.

50, 100 or 315 bar

S	Subplate mounting
T	Threaded body

All rights reserved.
Subject to revision.