



HAND PUMP HP10

ENGINEERING

1

Ref. No. P09700

Release 12/2001

Description

Heavy duty construction with hardened and ground piston.
Renewable Suction, Delivery, Relief and Release valve parts.
Integral Relief and Release valves.



Section

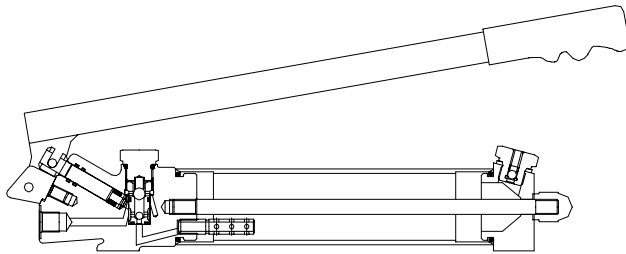

Hydraulic Symbol

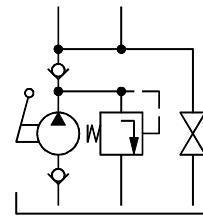

Unit dimension

HYDRO PNEUMATIC ACCESSORIES

W: <http://hpa.net.in> E: ina@hpa.net.in

Dimensions in mm.

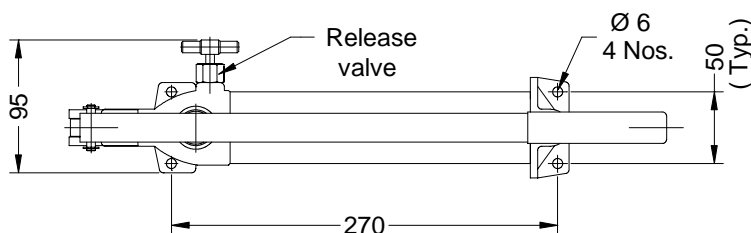
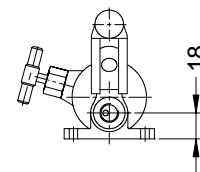
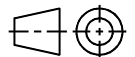
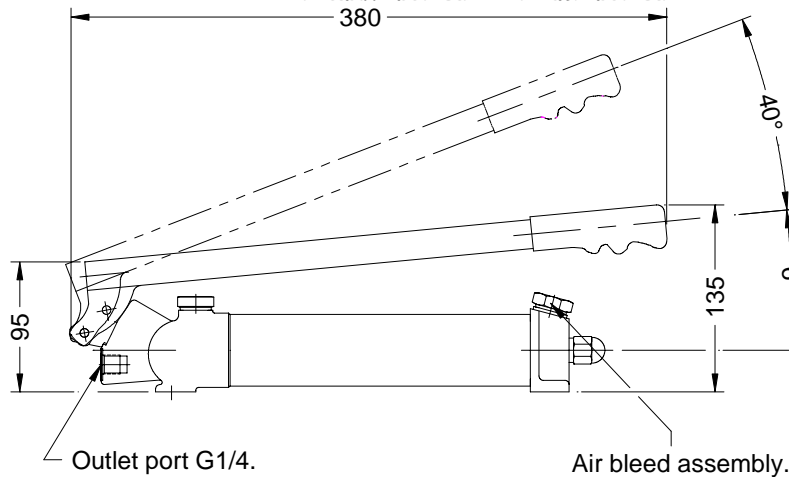

Polyhydron Pvt. Ltd.

78-80, Machhe Industrial Estate,
Machhe, Belgaum - 590 014. INDIA.

Phone : +91-(0)831-411001

Fax : +91-(0)831-411002

E-mail : polyhydron@vsnl.com

Website : www.polyhydron.com



HAND PUMP HP10

ENGINEERING

2

Ref. No. P09700

Technical specification

ConstructionSealed piston with ball type suction and delivery valve
Hydraulic mediumMineral oil (ISO VG 68 Grade recommended)
Maximum working pressureHP 10 & HP 10 - K350 bar
Flow capacityHP 10 & HP 10 - K1.25 cm³ / stroke
Oil tank capacity250 cc.
Oil tank displacement175 cc.
Force required at the end of the400 N. APPROX.
hand lever at max. pressure
Mass3.kgs. (without oil).

Ordering code



HYDRO PNEUMATIC ACCESSORIES
W: <http://hpa.net.in> E: inq@hpa.net.in

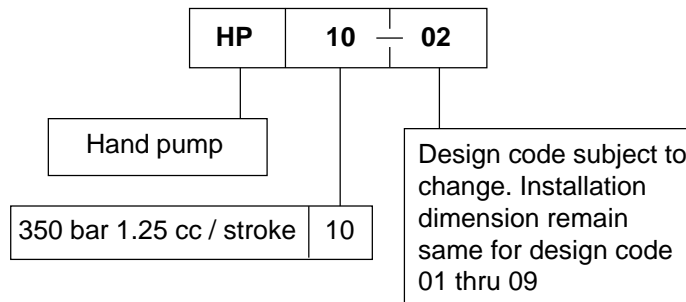



HAND PUMP HP10

SERVICE

3

Ref. No. P09700

Sectional View and Part List

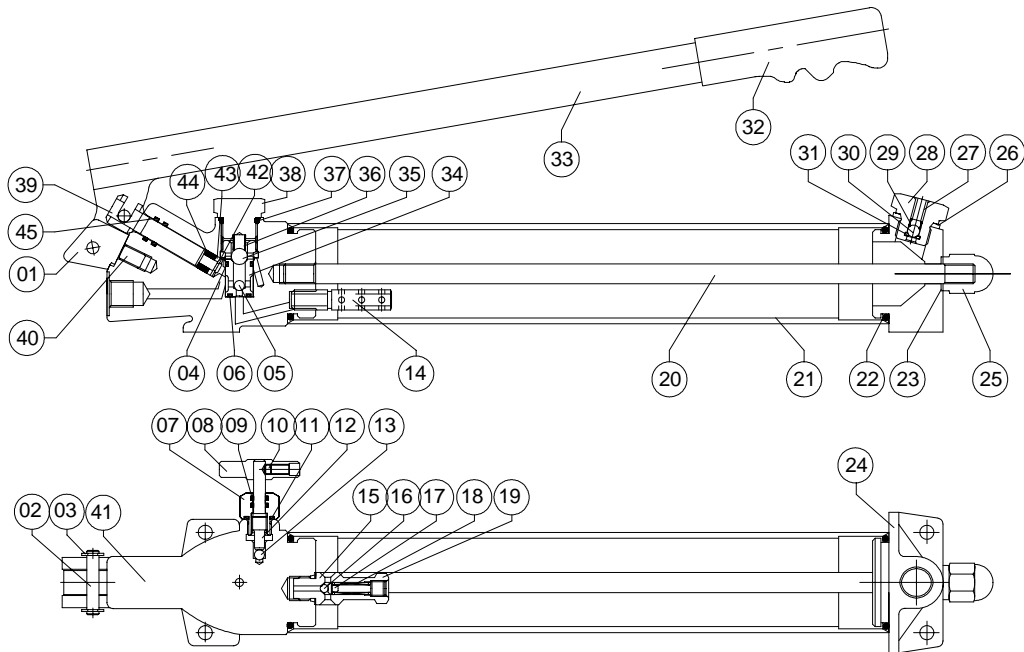

Hydraulic symbol

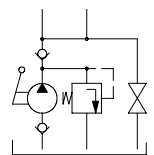

Part No.	Sl. No.	Description / Size	Qty.	Part No.	Sl. No.	Description / Size	Qty.
10201	01	Link	01	10225	25	Dome nut	01
10202	02	Handle pin	02	10226	26	Cu. washer	01
10203	03	Circlip	04	10227	27	Dowel pin	01
10204	* 04	'O' ring (10 id x 1.8 csd.)	02	10228	28	Air bleeder housing	01
10205	05	Ball	01	10229	29	Spring	01
10206	* 06	'O' ring (7 id x 1.8 csd.)	01	10230	30	Ball	01
10207	07	Spindle guide	01	10231	* 31	'O' ring (4.5 id x 1.8 csd.)	01
10208	08	Hand lever	01	10232	32	Grip	01
10209	* 09	'O' ring (6 id x 1.5 csd.)	02	10233	33	Handle	01
10210	10	Grub screw	01	10234	34	Suction / Delivery housing	01
10211	* 11	'O' ring (10 x 1.8 csd.)	01	10235	35	Ball	01
10212	12	Spindle	01	10236	36	Delivery valve spring	01
10213	13	Ball	01	10237	* 37	'O' ring (15 id x 2.5 csd.)	04
10214	14	Seamless pipe	01	10238	38	Delivery spring guide	01
10215	15	Relief valve seat	01	10239	39	Plunger	01
10216	16	Ball	01	10240	40	Link stud	01
10217	17	Ball locator	01	10241	41	Pump body	01
10218	18	Spring	01	10242	* 42	Fluid seal (10 od x 5 id x 6 th)	01
10219	19	Grub screw	01	10243	43	Spacer	01
10220	20	Tie rod	01	10244	44	Circlip	01
10221	21	Reservoir tube	01	10245	* 45	'O'ring (10 di x 1.8 csd.)	02
10222	* 22	'O' ring	02				
10223	23	Bonded seal	01				
10224	24	End cover	01				

Note : * Recommended spare kit.

While ordering the individual spares / spare kit / give Part no. and complete details of model code as on the label.



HAND PUMP
HP10

SERVICE

4

Ref. No. P09700

